

- **Air Speed Transmitter**
- **Temperature, Air speed transmitters**
- **Temperature, Relative Humidity and Air Speed Transmitters**
- **Hot wire Air Speed Transmitters**



HD2903T... HD29V3T...
HD2937T... HD29V37T...
HD29371T... HD29V371T...



Committed to the Customer since 1989

HTA INSTRUMENTATION (P) LTD.,

An ISO 9001: 2015 Certified Company & NABL Accredited Calibration Laboratory as per ISO/IEC 17025:2017

Your One Stop For Instrumentation Supply, Automation & Calibration

73, Ramachandra Agrahara, Near T.R. Mills, Chamarajpet, Bangalore - 560018, INDIA.

Phone : 080-26749750, 26759253, 26740681 E-mail : sales@htaipl.com Website : www.htaipl.com



ISO 9001:2015 CERTIFIED
 Certificate No. IQSC202010014

HD2903T... HD29V3T... HD2937T... HD29V37T...

HD29371T... HD29V371T...

Air Speed Transmitters

HD2903T... - HD29V3T... series

Temperature, Air speed transmitters

HD2937T... - HD29V37T... series

Temperature, Relative Humidity and Air speed transmitters

HD29371T... - HD29V371T... series

The HD29 series of transmitters... are used for controlling air speed for conditioning and ventilation applications (HVAC/BEMS) in the following sectors: **Pharmacy, Museums, Clean Rooms, Ventilation Ducts, Auditoria**, as well as industrial and civil sectors.

The sensors in combination with an accurate electronics guarantee precise and reliable measurements in the course of time.

The thin film sensor for Air Speed, the AISI304 probe sheath, the 20µ metal grid filter for Relative Humidity enable their usage even for hostile applications.

There are two possible installations: in the TO version, the horizontal probe is joined to the electronics enclosure while in the TC version the probe is connected to the electronics through a cable.

In the TO version, the duct probe is fixed to the electronics enclosure and it is available in three different lengths. To fix the probe to the duct, you can use, for example, the HD9008.31 flange, a 3/8" universal biconical connection or a PG16 metal cable gland (ø10...14mm).

In the TC version, the probe together with the sensors is equipped with a cable which can be 2, 5 or 10 meters long. The probes are available in three different lengths.

Common Technical Specification **Notes**

Air speed Measuring range	0.05...1m/s 0.05...2m/s 0.05...10m/s 0.05...20m/s	The measuring range can be selected by dip-switch.
Air speed Accuracy range 0...1m/s range 0...2m/s range 0...10m/s range 0...20m/s	±(0.04m/s+2% of measurement) ±(0.04m/s+2% of measurement) ±(0.2m/s+3% of measurement) ±(0.2m/s+3% of measurement)	at 50%RH and 1013hPa
Temperature Measuring range	-10...+60°C	HD2937, HD29V37, HD29371 and HD29V371 models
Temperature Accuracy	±0.3°C	
RH Measuring Range	5...98%RH	
Relative Humidity Accuracy	±2% (5...90%RH), models ±2.5% remaining range	HD29371 and HD29V371 models
Relative Humidity Output Range	0...100%RH	
Output (according to the models)	4...20mA 0...10Vdc	R _L < 500Ω R _L > 10kΩ
Power supply	16...40Vdc or 12...24Vac±10%	
Response time (selected by jumper)	0.2s 2.0s	Fast Slow
Operating temperature electronics probe	0...+60°C -30...+100°C	
Compensation temperature	0...+80°C	
Storage temperature	-10...+70°C	
Electronics protection class	IP67	
Sensor working conditions	Clean air, RH < 90%	
Case dimensions	80 x 84 x 44	Without probe



Model Description

Model	Output		MeasureParameters		
	4...20mA	0...10Vdc	Air speed	Temp.	Relative Humidity
HD2903T...	•		•		
HD29V3T...		•	•		
HD2937T...	•		•	•	
HD29V37T...		•	•	•	
HD29371T...	•		•	•	•
HD29V371T...		•	•	•	•

Installation notes

- The sensor(s) hole must be oriented in the same direction as the flow: to help position the probe, for example inside a Duct, a Graduated Scale along the stem shows how deep the air speed sensor hole is inside the duct. Once the sensor is inside the duct, to orient it properly according to the flow, make sure that the air speed passing hole and the line at the bottom of the graduated scale are on the same axis.

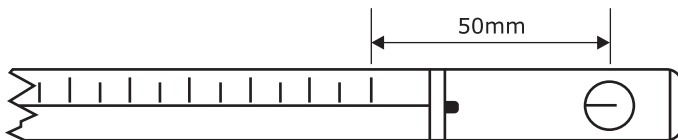

- To fix the probe inside a ventilation duct, a pipe, etc. you can use, for example, **HD9008.31** flange, a PG16 metal cable gland ($\varnothing 10...14\text{mm}$) or a 3/8" universal biconical connection.



HD9008.31 Flange

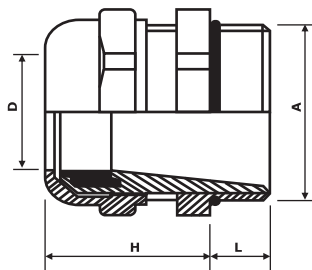

PG16 metal cable gland
 D = 10...14mm
 L = 6.5mm
 H = 23mm
 A = PG16

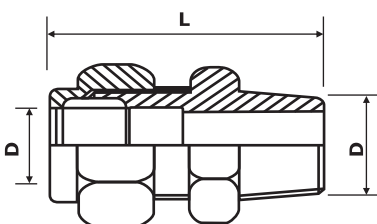

Universal biconical connector
 L = 35mm
 D = 14mm
 A = 3/8"





- The transmitters are factory calibrated and no further adjustments are required.
- To select the air speed **output range** by using the dual dip-switch on the board, please see the chart below:

Output range	0...1m/s	0...2m/s	0...10m/s	0...20m/s
Dip-switch position				

- The jumper on the board selects an **integrated response time in 0.2s in the FAST position and in 2s in the SLOW position. Please set the integration time at SLOW in case of turbulence, otherwise please select the FAST position.**

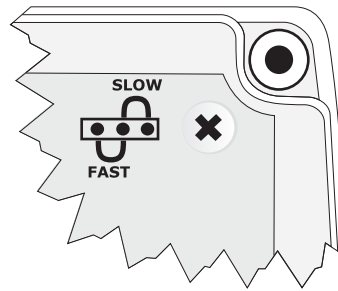

► Installation notes

Power supply

Power the instrument at the voltage shown in the Electrical Specifications: Power Supply Terminals are marked as +Vcc and GND.

Analogue Output

According to the Model, the output signal comes from:

- VEL and GND terminals for Air Speed Transmitters,
- VEL and GND, Temp and GND Terminals for Temperature / Air Speed Transmitters,
- VEL and GND, Temp and GND, %RH and GND Terminals for Temperature / Relative Humidity / Air Speed Transmitters.

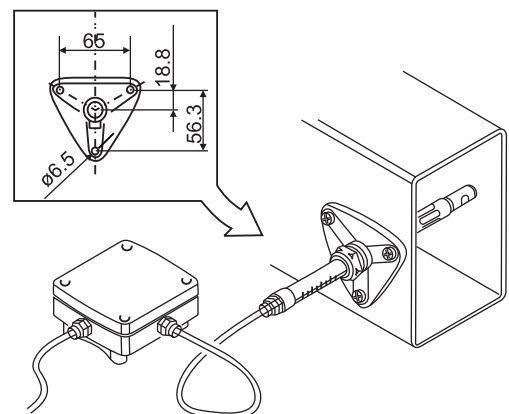
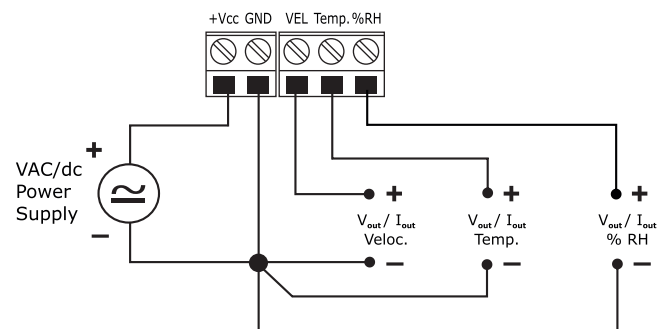

► **HD2903T... and HD29V3T... ORDERING CODES**

HD2903T...: Active transmitter for measuring air speed in ducts, 4...20mA output. AISI 304 steel probe, diameter 12mm, compact unit HD2903TO... version with probe joined to the electronics enclosure, HD2903TC... version with probe connected to the electronics through a cable. Air speed range 0...1m/s - 0...2m/s - 0...10m/s - 0...20m/s selected by jumper. Power supply 16...40Vdc or 12...24Vac. Air probe operating temperature -30°+100°C.

HD29V3T...: Active transmitter for measuring air speed in ducts, 0...10Vdc output. AISI 304 steel probe, diameter 12mm, compact unit HD29V3TO... version with probe joined to the electronics enclosure, HD29V3TC... version with probe connected to the electronics through a cable. Air speed range 0...1m/s - 0...2m/s - 0...10m/s - 0...20m/s selected by jumper. Power supply 16...40Vdc or 12...24Vac. Air probe operating temperature -30°+100°C.

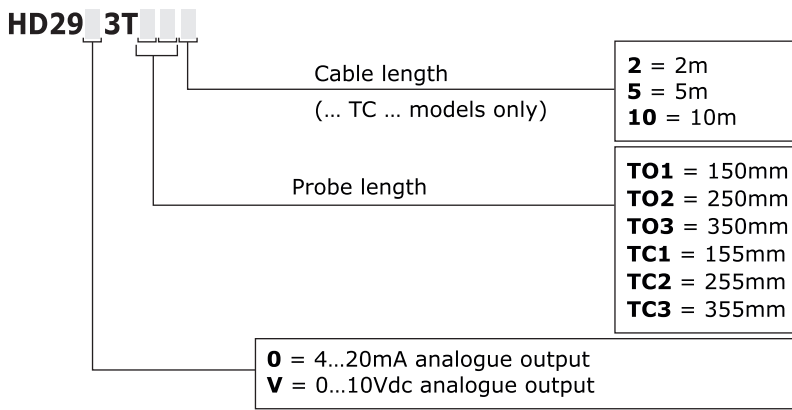

► **Dimension**

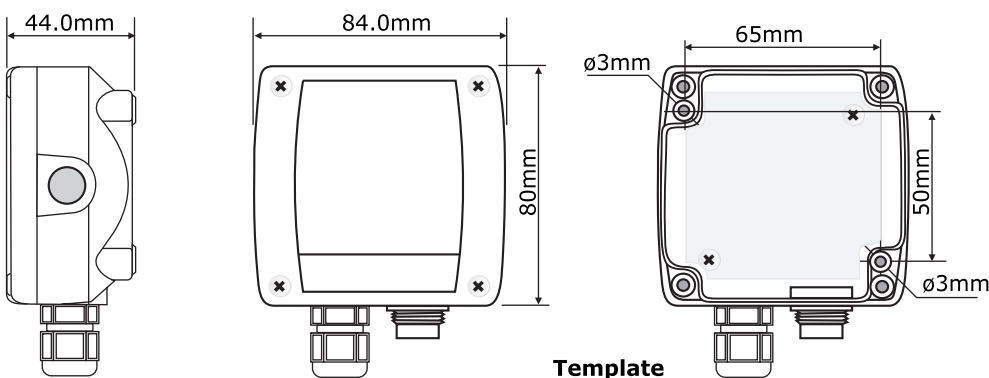

▶ **HD2937T... and HD29V37T... ORDERING CODES**

HD2937T...: Active transmitter for measuring air speed and temperature in ducts, 4...20mA outputs. AISI 304 steel probe, diameter 12mm, compact unit HD2937TO...version with probe joined to the electronics enclosure, HD2937TC... version with probe connected to the electronics through a cable. Air speed range 0...1m/s - 0...2m/s - 0...10m/s - 0...20m/s selected by jumper, fixed temperature range -10...+60°C. Power supply 16...40Vdc or 12...24Vac. Air probe operating temperature -30°+100°C.

HD29V37T...: Active transmitter for measuring air speed and temperature in ducts, 0...10Vdc outputs. AISI 304 steel probe, diameter 12mm, compact unit HD29V37TO...version with probe joined to the electronics enclosure, HD29V37TC... version with probe connected to the electronics through a cable. Air speed range 0...1m/s - 0...2m/s - 0...10m/s - 0...20m/s selected by jumper, fixed temperature range -10...+60°C. Power supply 16...40Vdc or 12...24Vac. Air probe operating temperature -30°+100°C.

▶ **HD29371T... and HD29V371T... ORDERING CODES**

HD29371T...: Active transmitter for measuring air speed, temperature and relative humidity in ducts, 4...20mA outputs. AISI 304 steel probe, diameter 14mm, compact unit HD29371TO version... with probe joined to the electronics enclosure, HD29371TC... version with probe connected to the electronics through a cable. Air speed range 0...1m/s - 0...2m/s - 0...10m/s - 0...20m/s selected by jumper, fixed temperature range -10...+60°C, relative humidity range 0...100%RH. Power supply 16...40Vdc or 12...24Vac. Air probe operating temperature -30°+100°C.

HD29V371T...: Active transmitter for measuring air speed, temperature and relative humidity in ducts, 0...10Vdc outputs. AISI 304 steel probe, diameter 14mm, compact unit HD29V371TO...version with probe joined to the electronics enclosure, HD29V371TC... version with probe connected to the electronics through a cable. Air speed range 0...1m/s - 0...2m/s - 0...10m/s - 0...20m/s selected by jumper, fixed temperature range -10...+60°C, relative humidity range 0...100%RH. Power supply 16...40Vdc or 12...24Vac. Air probe operating temperature -30°+100°C.

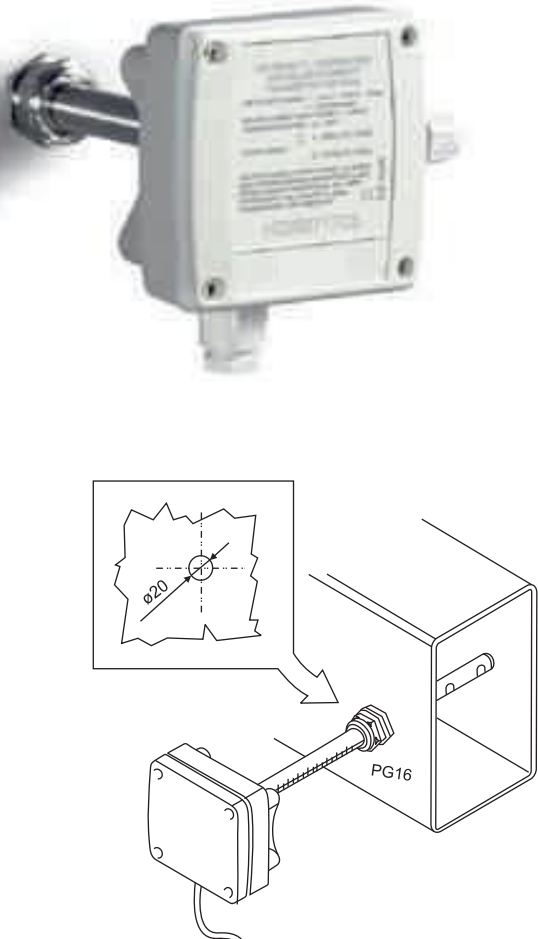
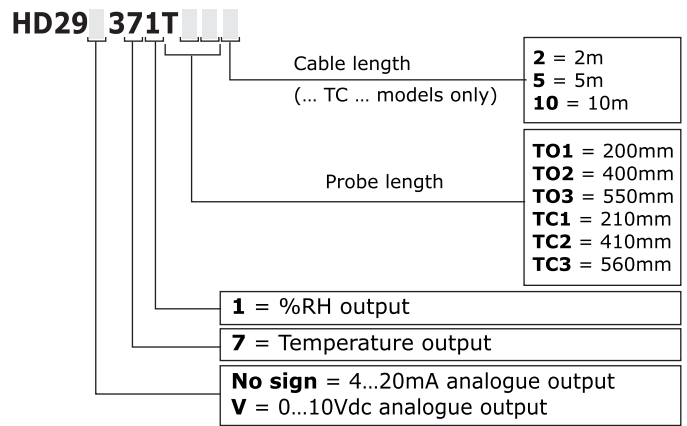
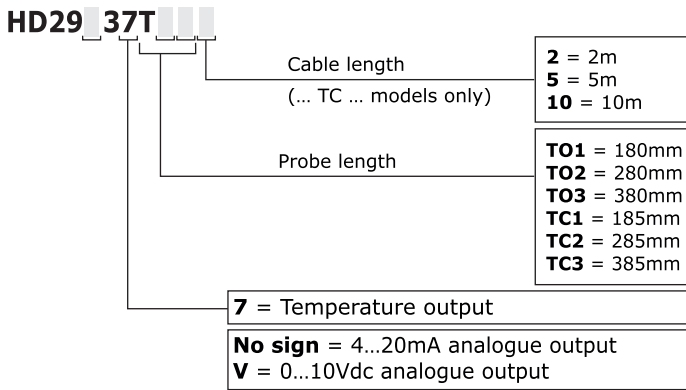

▶ **Probe Dimensions :**

TO Series

